

SSZC50



MERKMALE:

Kanal-Überdruckklappe,
Abstand 50 mm.

AUSFÜHRUNG:

Rahmen aus verzinktem
Stahlblech.
Lamellen aus extrudiertem
Aluminium.

BEFESTIGUNG:

Durch Bolzen an den
Flanschecken.

CHARACTERISTICS:

Duct overpressure dampers
50 mm pitch.

CONSTRUCTION:

Galvanized steel frame.
Extruded aluminium blades.

FIXING:

By bolts on flanges corners.

PREISE - PRICES

↑	BASE B mm							
	300	400	600	800	1000	1200	1400	1600
H mm	€	€	€	€	€	€	€	€
210	74,20	80,13	93,98	107,82	120,68	136,49	176,08	191,88
310	80,13	90,02	106,82	121,67	136,49	163,23	197,82	216,62
410	92,99	100,90	119,60	136,49	152,31	170,14	220,57	242,34
510	101,88	111,78	131,55	150,35	169,13	186,95	243,32	268,06
610	110,77	122,64	142,44	165,19	184,96	204,76	268,06	294,01
810	134,53	145,39	170,14	194,84	216,62	238,38	312,55	344,22
1010	149,72	166,18	195,86	223,55	248,25	272,02	358,07	394,66

Serrande comprese di divisorio - Dampers including the dividing

SSZC5080 + 10%

ZEICHNUNGEN - DRAWINGS

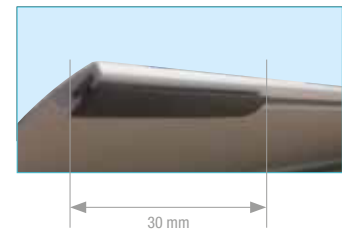
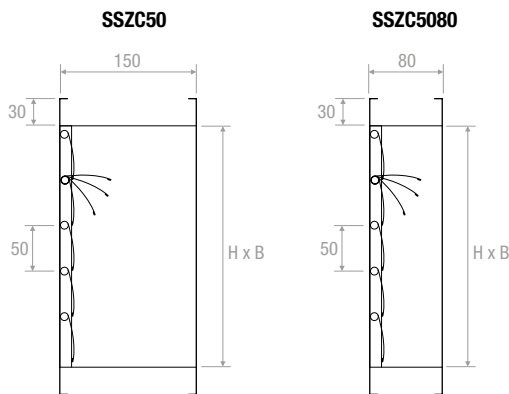

Serienmäßige Anschläge laut Foto
Preis für stufenlose, schalldämpfende Dichtung
+ 15%

Series swabs as picture
Aphonic continuous seal price + 15%

AUSWAHLTABELLE - SELECTION TABLE

Modell - Model	A ₁ [m ²]	v [m/s]		Q [m ³ /h]		Dp [Pa]		L _{WA} [dB(A)]	
		min	max	min	max	min	max	min	max
SSZC50 400x210	0,0840	3,3	6,5	1010	1970	40	120	37	44
SSZC50 600x210	0,1260	3,2	6,3	1460	2850	40	120	37	45
SSZC50 800x210	0,1680	3,1	6,1	1900	3710	40	120	38	45
SSZC50 1000x210	0,2100	3,1	6,0	2330	4550	40	120	38	46
SSZC50 1200x210	0,2520	3,0	5,9	2750	5370	40	120	38	46
SSZC50 1400x210	0,2940	3,0	5,8	3170	6190	40	120	39	46
SSZC50 400x410	0,1640	3,2	6,1	1860	3630	40	120	38	45
SSZC50 600x410 - 400x610	0,2460	3,0	5,9	2690	5260	40	120	38	46
SSZC50 800x410 - 400x810	0,3280	3,0	5,8	3500	6840	40	120	39	46
SSZC50 1000x410 - 400x1010	0,4100	2,9	5,7	4290	8390	40	120	39	47
SSZC50 1200x410	0,4920	2,9	5,6	5070	9910	40	120	39	47
SSZC50 1400x410	0,5740	2,8	5,5	5840	11410	40	120	40	47
SSZC50 1600x410	0,6560	2,8	5,5	6600	12900	40	120	40	48
SSZC50 600x610	0,3660	2,9	5,7	3870	7560	40	120	39	47
SSZC50 800x610 - 600x810	0,4880	2,9	5,6	5030	9840	40	120	39	47
SSZC50 1000x610 - 600x1010	0,6100	2,8	5,5	6170	12070	40	120	40	47
SSZC50 1200x610	0,7320	2,8	5,4	7290	14260	40	120	40	48
SSZC50 1400x610	0,8540	2,7	5,3	8400	16420	40	120	40	48
SSZC50 1600x610	0,9760	2,7	5,3	9490	18550	40	120	40	48
SSZC50 800x810	0,6480	2,8	5,5	6520	12750	40	120	40	47
SSZC50 1000x810 - 800x1010	0,8100	2,7	5,4	8000	15640	40	120	40	48
SSZC50 1200x810	0,9720	2,7	5,3	9450	18480	40	120	40	48
SSZC50 1400x810	1,1340	2,7	5,2	10890	21280	40	120	41	48
SSZC50 1600x810	1,2960	2,6	5,2	12300	24050	40	120	41	49
SSZC50 1000x1010	1,0100	2,7	5,3	9790	19140	40	120	40	48
SSZC50 1200x1010	1,2120	2,7	5,2	11570	22620	40	120	41	48
SSZC50 1400x1010	1,4140	2,6	5,1	13320	26040	40	120	41	49
SSZC50 1600x1010	1,6160	2,6	5,1	15050	29430	40	120	41	49

SCHNELLAUSLEGUNG - QUICK SELECTION DIAGRAM

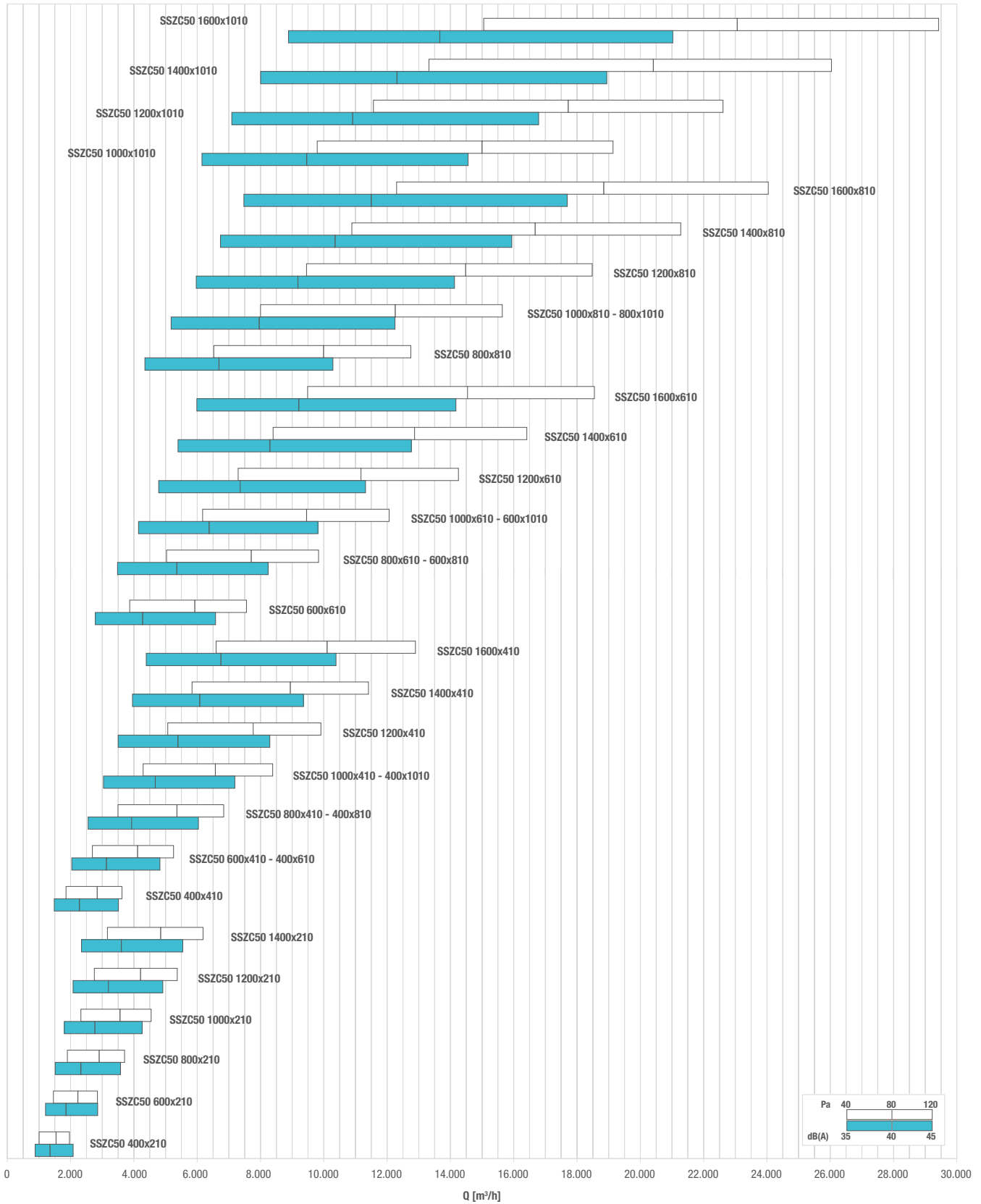

REG